



Professional Awning
Manufacturers Association



Telescopic Pole



Manual for
Installation, Use and
Maintenance



All information contained in this document was provided by the manufacturer of the components of this model. As a fabricator, Retractableawnings.com claims no liability with respect to these documents as we are not engineers and did not complete any of the information, engineering or calculations in this document.

SUMMARY

1	Introduction	4
1.1	▪ Symbols Used in the Manual	4
1.2	▪ Personnel Requirements.....	4
1.3	▪ Required Equipment.....	4
1.4	▪ Contents of packaging	5
2	Safety	5
2.1	▪ General Safety Information	5
2.2	▪ Requirements for Working in Safety	5
2.3	▪ Working Environment.....	6
3	Description of the Accessory	6
3.1	▪ Intended Use	6
3.2	▪ Load Calculation for Plugs to Fasten the Telescopic Pole to the Ground	7
3.3	▪ Table of Suggested Anchoring Devices	8
3.3.1	▪ Types of Anchoring Devices Based on Base Material	
3.3.2	▪ Sequence for Fastening of Anchoring Devices	9
3.4	▪ Components	10
3.4.1	▪ Joint.....	10
3.4.2	▪ Telescopic pole	10
3.4.3	▪ Ground Fastening Plate.....	10
4	Special Maintenance	12
4.1	▪ Troubleshooting table.....	12

1 INTRODUCTION

This manual for the **Telescopic Pole** was prepared by the manufacturer to provide necessary information to those authorized to install and perform special maintenance of the product. It is prohibited to remove, rewrite or in any way modify the pages of the manual and their content.

Operations must be carried out by personnel with the technical and professional skills required by current applicable national laws or standards.

This manual must be kept complete in all its parts in an easily accessible place.

If the manual is lost or destroyed, the client must request a new copy, providing the main product data and the destination of the new copy.

The manufacturer reserves the right to update products and corresponding manuals without the obligation to update previous products and manuals.

The manufacturer reserves all rights on this manual. It may not be reproduced in any way, wholly or in part, without the manufacturer's written authorization.

Any tampering or modification to the product without the proper authorization of the manufacturer relieves the manufacturer of any liability for damage that may arise.

1.1 Symbols used in the manual

The WARNING symbols used in the manual are shown below.



INFORMATION AND PRECAUTIONS

Useful suggestions and instructions to ensure proper assembly. Failure to observe these messages may compromise the integrity and/or the resistance of the product.



ATTENTION

DANGER TO OPERATOR! Instructions to be evaluated and followed carefully. Failure to comply with these messages may compromise individual safety.

1.2 Personnel requirements

Personnel assigned to this operation must have technical knowledge of the product obtained either through two years' experience or by means of a suitable technical training course.

1.3 Required equipment

To ensure proper installation of the awning, and consequently best operation of the finished product, the following equipment is required:

- power screwdriver;
- a level;
- string;
- complete tool set;
- equipment for working at heights (scaffolding, ladders, aerial platforms, etc.) which are compliant with current standards of individual safety in the workplace.



ATTENTION

All of the screws used on aluminium components must be tightened with a maximum force of 20 Nm (= 2 kgm). Greater tightening force causes the breakage of fusions and damage to the stainless steel screws. It is advisable to use torque wrenches and screwdrivers.



ATTENTION

Use low-speed power screwdrivers. Screwing in the stainless steel screws at high speed may cause the threads to jam, especially in the case of stainless steel/stainless steel and stainless steel/ aluminium screws and threads.

1.4· Contents of packaging

i INFORMATION AND PRECAUTIONS

Never move the accessories from the position in which they are supplied.

2 SAFETY

2.1· General safety information

- During all operations described in this manual, make sure that **ONLY** individuals involved in the work are in the work zone (see Chap. 1.2 "Personnel requirements").
- In case of rain, wind or snow, close the awning completely. Danger of personal injury or property damage.
- Make sure that when opening/closing the awning, there are no individuals within its range of action.
- Do not set objects on the canvas of the awning.
- IT IS prohibited to stand on or hang from the awning. This would create the risk of severe personal injury, as well as damaging the awning.
- If you have any doubts, contact the retailer BEFORE using the awning.
- The user must not undertake on his own initiative any sort of work on the awning which are not his responsibility (see Chap. 3.1 "Intended Use" and Chap. 6 "Special Maintenance").
- Any tampering or modification without the authorization of the manufacturer relieves the manufacturer of any liability for damage which may arise.
- The user is required to inform the retailer promptly if he discovers any defects and/or malfunctions in the safety devices or if any hazardous situation should occur.
- Installation, first start-up, adjustment and special maintenance must only be carried out by specialized technical personnel who are qualified for those duties. Contact technical service.

! ATTENTION

Installation, adjustment, and special maintenance of the awning must be carried out only by specialized, skilled technical personnel.

! ATTENTION

It is necessary to ensure a distance of at least 500 mm between the end of the fully-opened awning (outermost part) and any fixed obstacle (wall, terrace, etc.).

i ATTENTION

IT IS prohibited to install or place ladders or other objects near the awning, as this would reduce the space required for installation.

i ATTENTION

Never loosen the awning more than the tension in the arms as there is the risk that the awning return under the tube and be ruined.

2.2· Requirements for working in safety

- Installation must be performed in full compliance with standards set forth by Presidential Decree 164/56 and Legislative Decree 494/96 for all that which concerns individual safety.
- Before use, check that all temporary structures (scaffolding, ladders, etc.) and all individual safety gear (harnesses, belts, etc.) are compliant with standards and in good condition.

- Always use suitable individual protection gear.
- If there is more than one installation technician, their work must be coordinated.
- Operators must work in compliance with the safety instructions given to them.
- If the awning is to be installed above ground level, the area underneath the awning must be marked off and guarded so that no one can get underneath the hanging load.
- Firmly tie the ropes or straps around the arm supports so that it does not slip and risk falling.

2.3- Working environment

- Assembly of the accessory must be carried out in a place that is sufficiently illuminated (based on specific standards) by either natural or artificial lighting. The operator must have a clear view of the work to be performed, **and he must also prevent third persons from approaching the work area around the awning.**

3 DESCRIPTION OF THE ACCESSORY

The Telescopic Pole is an accessory that is fastened to the end of the awning in question and serves to reduce swinging. Attachment to the awning tube is very simple and it is very easy to use.

It consists of a tube with an external diameter of \varnothing 26 mm that can vary in height from a minimum of 150 cm to a maximum of 300 cm.

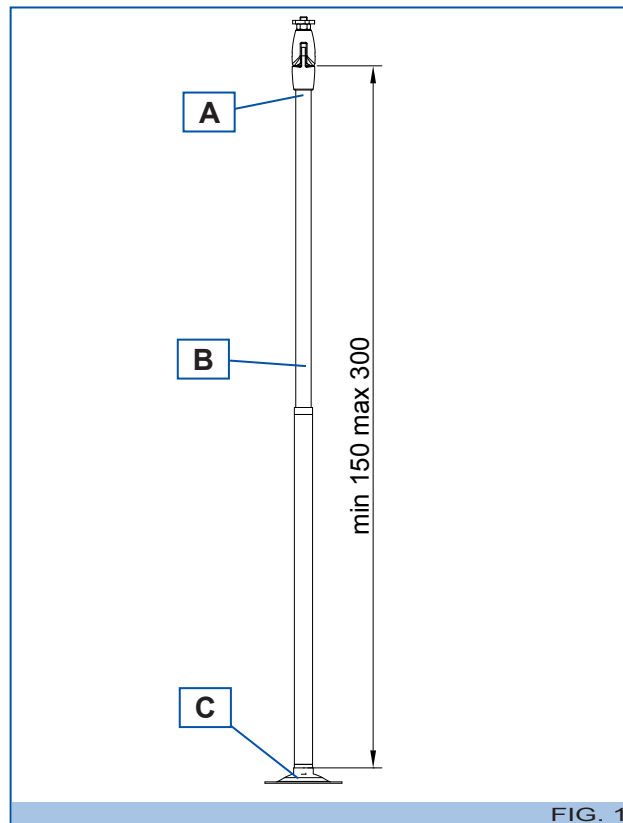

3.1- Intended Use

The telescopic pole can be used with all awnings with arms except boxed ones and ones with bottom rails. It stabilizes the awning thanks to its attachment to the ground.

ATTENTION

ANY USE other than the aforementioned is prohibited, since the operating conditions may create hazards for individuals.

Improper use resolves the manufacturer of any damage caused to persons or property. Failure to comply with the conditions of use automatically voids any type of guarantee provided by the manufacturer.

! ATTENTION

In case of rain, wind or snow, retract the pole and CLOSE the awning completely. Danger of personal injury or property damage.

! ATTENTION

Do not use the telescopic pole with electronic control units or deactivate the control unit.

3.2 · Load Calculation for Plugs to Fasten the Telescopic Pole to the Ground

A calculation for the plugs based on the ground fastening holes must be performed to install the telescopic pole.

i INFORMATION AND PRECAUTIONS

The plug calculation has been simulated for an approx. 600 cm x 500 cm Class 2 awning, single module, taking into account the use of all holes (D) in the plate (see the figure below). For all other awning sizes, use the same plug.

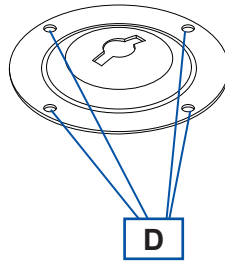

The value of the simulated plug calculation is 0.13 kN and expresses the extraction load on the most highly stressed plug. These values are required for the selection of the most suitable anchoring, based on the type of material upon which the awning will be installed. Choose the anchoring by referring to the recommended load values in the Hilti General Catalogue.

Ex: installation of the ground fastening plate

awning dimensions: 6x5

load on plug: 0.13 kN

base material: non-cracked concrete

Suggested plug: Hilti HST M6 or HST M8 (see technical characteristics of plugs in Hilti General Catalogue).

3.3- TABLE OF SUGGESTED ANCHORING DEVICES









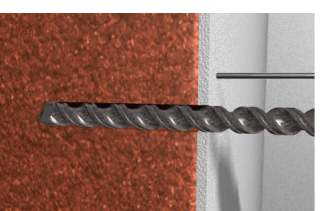

3.3.1 - Types of Anchoring Devices Based on Base Material

Extraction load on anchoring devices (kN)		
Hilti HST		CONCRETE CRACKED CONCRETE HARD NATURAL STONE
Hilti HSA		CONCRETE HARD NATURAL STONE
Hilti HIT-HY 150 with HAS		CONCRETE
Hilti HIT-RE 500 with HAS		CONCRETE HARD NATURAL STONE SOLID BRICK WOOD
Hilti HIT-HY 50		BETON GAS SOLID BRICK WOOD
Hilti HIT-HY 20		PERFORATED BRICK

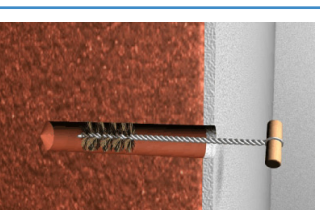
i INFORMATION AND PRECAUTIONS

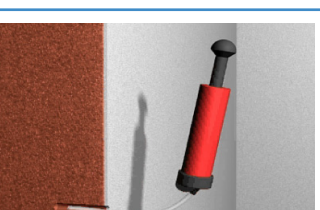
For corrosive environments, we suggest using stainless steel anchoring devices. For additional information, contact Hilti Italia S.p.A. technical service (e-mail:tecnici@hilti.com).

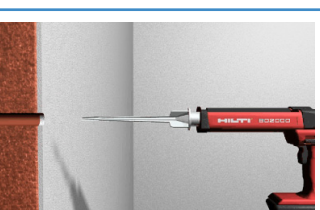
3.3.2 ▪ Sequence for Fastening of Anchoring Devices

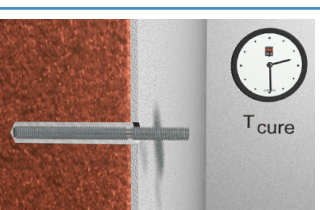
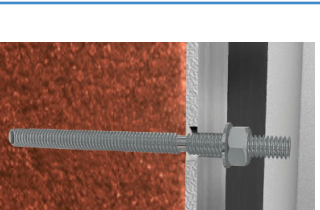
MECHANICAL ANCHORING DEVICE		CHEMICAL ANCHORING DEVICE	
	1º Make a hole with a drill bit that is suitable for the anchoring device		1º Make a hole with a drill bit that is suitable for the anchoring device
	2º Pay attention to how deep you make the hole		2º Pay attention to how deep you make the hole
	3º Remove dust and debris from the hole (preferably using compressed air)		3º Remove dust and debris using a brush
	4º Install the anchoring device		4º Remove residual dust with compressed air
	5º Tighten to the recommended tightening torque (see Hilti General Catalogue)		5º Inject the chemical adhesive
	6º Final configuration		6º Insert and settle the anchoring device. Comply with the setting time required before placing the plate (see product cartridge)
			7º After the time “T cure” has elapsed, position the plate, and tighten to the recommended tightening torque (see Hilti General Catalogue)

! ATTENTION

For proper installation of the anchoring devices, refer to the Hilti General Catalogue

! ATTENTION

The selection of the most suitable type of fastening device depends on the base material and its physical condition. It is therefore the responsibility of the installer to check the condition of the base material before attaching the awning. The installer is not obliged to use Hilti plugs.

3.4 - Components

The telescopic pole is divided into three parts:

- a joint with slide pin (A - Fig.1 page 6)
- a telescopic pole (B - Fig. 1 page 6)
- a ground attachment plate (C - Fig. 1 page 6).

3.4.1 - Joint

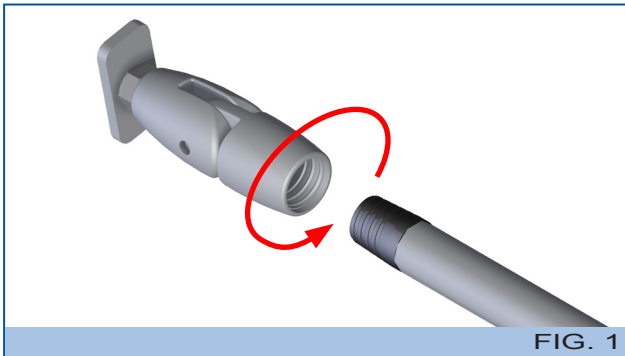

1^o Fasten the pole to the joint by turning it counter-clockwise, as shown in Figure 1.

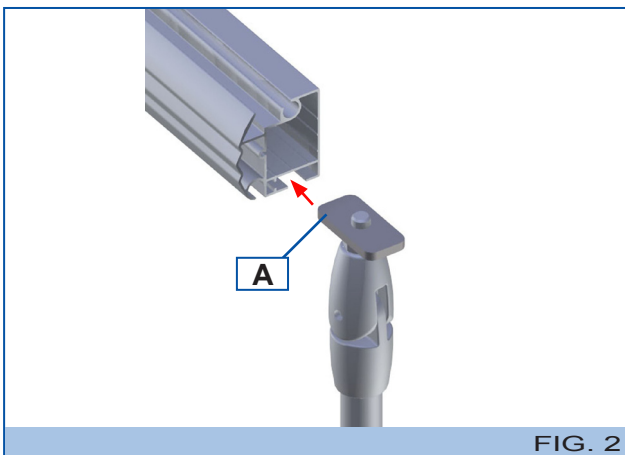

2^o Insert the slide plate (A) in the end of the installed awning. After determining the permanent position for the pole, fasten the slide.

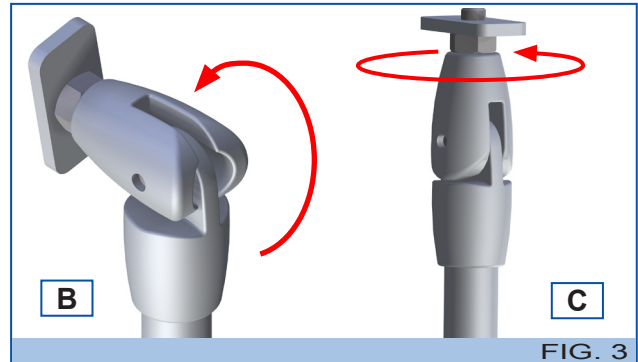

i INFORMATION AND PRECAUTIONS

The joint can turn 90° vertically (B) and 360° horizontally (C) (see Figure 3).

3.4.2 - Telescopic Pole

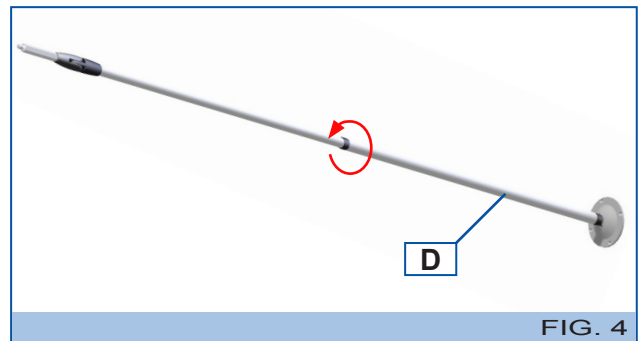

3^o Holding the bottom part (D) still, turn the pole counter-clockwise to lengthen and clockwise to fasten the pole in the desired position.

3.4.3 - Ground Fastening Plate

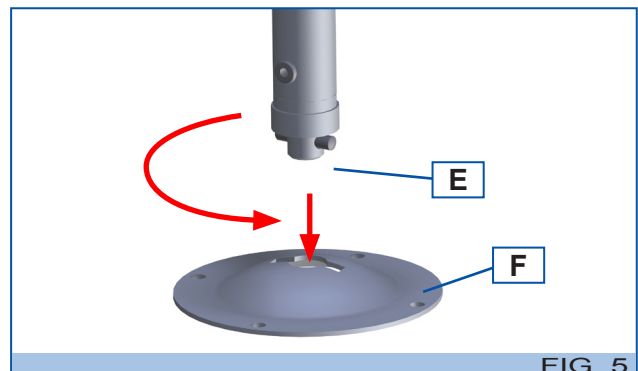

4^o Insert the plug pin (E) in the hole on the ground fastening plate (F) and turn it 90° to fasten the plug to the plate.

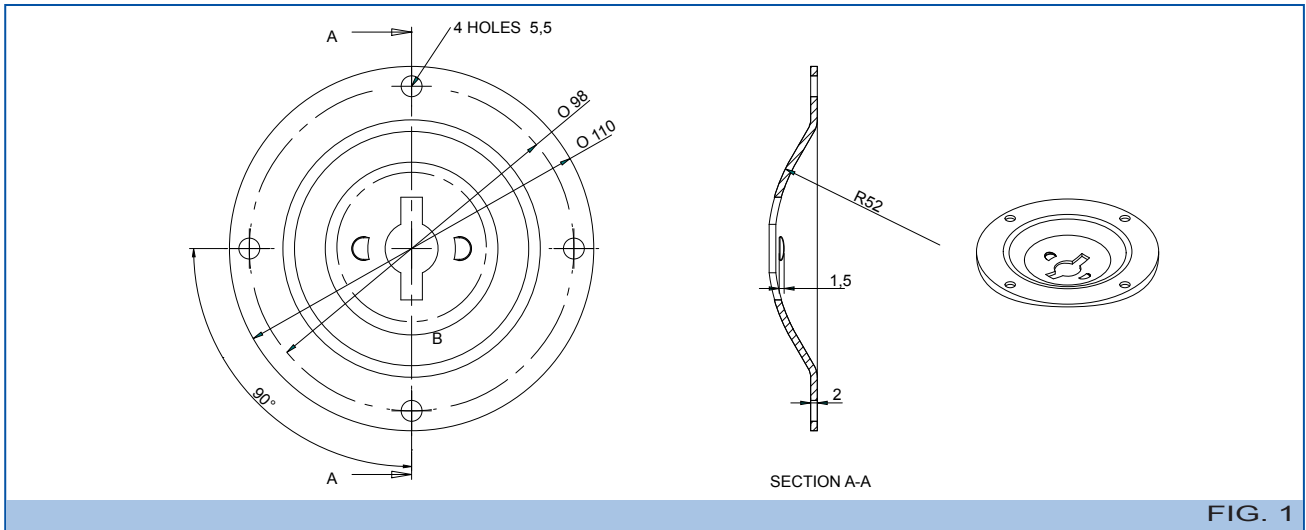

FIG. 1

i INFORMATION AND PRECAUTIONS

To make installation easier, you can print this page in A4 format and use it as a template to find the best position for the holes.

! ATTENTION

TO AVOID GROSS ERRORS, MAKE SURE THE PRINT OUT SCALE IS 1:1, CHECKING THE MEASURE INDICATED ON THE PAPER WITH A RULER OR CALLIPER IN RELATION TO THE DIMENSIONS INDICATED ABOVE.

GROUND FASTENING PLATE

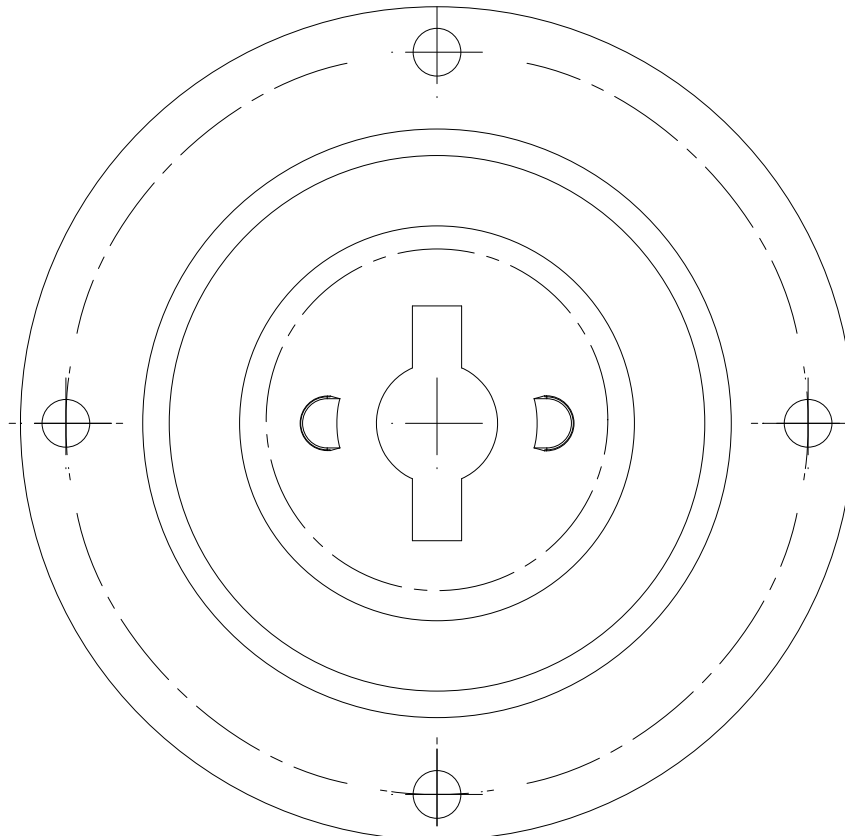

SCALE 1:1

4 SPECIAL MAINTENANCE

4.1 Troubleshooting Table

MANUAL AWNING

PROBLEMS	CAUSES	SOLUTIONS
Conical rolling of canvas	Uneven fabric thickness	Roll the canvass all the way back up

MOTORIZED AWNING

Without electronic control unit

PROBLEMS	CAUSES	SOLUTIONS
Conical rolling of canvas	Uneven fabric thickness	Roll the canvass all the way back up
The awning does not roll up all the way.	Incorrect adjustment of limit switch	See manual for motor (attached)
The awning does not open up all the way.	Movement of motor crown during operation	See manual for Assembly, Chap. 7
The motor is very noisy	Incorrect wiring	See manual for motor (attached)
	Motor defective	See manual for motor (attached)
The motor shuts down after 4-5 minutes of continuous use	Thermal protection of motor trips	Let the motor cool off for a few minutes



Professional Awning
Manufacturers Association



Manufacturing Facility:

Retractableawnings.com
16255 NW 54 Avenue
Miami Gardens, Florida 33014-6106
United States of America
Telephone (305) 628-2424
Telephone Toll Free 1 (866) 438-2964
Fax (305) 623-0099
Email sales@retractableawnings.com

Instant Messaging:

GOOGLTALK -retractableawnings
SKYPE - retractableawnings
MSN - retractableawning
YAHOO - retractableawnings
AOL - retractableawn
ICQ - 166644911

